



Study of the effect of bolt diameter and washer on damping in layered and jointed structures

B.K. Nanda

Mechanical Engineering Department, National Institute of Technology, Rourkela 769008, Orissa, India

Received 18 June 2004; received in revised form 9 May 2005; accepted 23 May 2005

Available online 25 August 2005

Abstract

In the present work, the mechanism of damping in layered and jointed structures with connecting bolts and washers have been extensively studied. A lot of experiments have been conducted on a number of specimens with connecting bolts of various diameters to study its effect on the damping capacity of the layered and jointed structures and to establish the authenticity of the theory developed. Intensity of interface pressure, diameter of the connecting bolts, washers, number of layers, kinematic coefficient of friction at the interfaces and frequency and amplitude of excitation are found to play a major role on the damping capacity of such structures. It is established that the damping capacity of structures jointed with connecting bolts can be improved substantially by increasing the number of layers connected with bolts of smaller diameters along with use of washers.

© 2005 Elsevier Ltd. All rights reserved.

1. Introduction

Over the years, the study of damping mechanism and its improvement in structures has become significant in effectively controlling the undesirable effects of vibration with simultaneously aiming at enhancing the damping capacity. As the available damping in the structural members is inadequate, various techniques have been adopted in practice to improve the damping capacity of structures. These techniques are: (i) use of constrained/unconstrained viscoelastic layers, (ii) fabrication of multi-layered sandwich construction, (iii) insertion of special high elastic inserts

E-mail address: bknanda@nitrkl.ac.in.

in the parent structure, (iv) application of spaced damping techniques and, (v) fabricating layered and jointed structures with welded/riveted/bolted joints. Such structures can be designed and fabricated effectively depending on the required damping capacity of the structures by suitably controlling the influencing parameters.

The logarithmic damping decrement, a measure of damping capacity of layered and jointed structures is determined by the energy principle considering the interface pressure and the relative dynamic slip at the interfaces of the contacting layers. In order to obtain the damping capacity of such structures correctly, these two major parameters are to be measured accurately. Previous investigators such as Fernlund [1], Kobayashi and Matsubayashi [2,3] and Shin et al. [4] have reported on this interface pressure and its distribution characteristics without specifying the spacing of the connecting bolts between them. Extensive work has been reported by Masuko et al. [5], Nishiwaki et al. [6,7] and Motosh [8] on damping capacity of such structures assuming uniform pressure distribution at the interfaces of the layered and jointed structures without considering the actual pattern but by using Röttschar’s pressure cone [5]. Connolly and Thornley [9] and Mitsunaga [10] have shown that the pressure distribution at the jointed interfaces is not uniform but varies almost parabolically being maximum at the surface of the bolt hole. Further, Gould and Mikic [11] and Ziada and Abd [12] have established that there exists an influence zone under each such bolt which is independent of the tightening load on the bolt. This zone is found to be a circle around the centre of the bolt with a diameter equal to 3.5 times its own diameter as shown in Fig. 1. Nanda [13] and Nanda and Behera [14–16] have also done considerable amount of work on the distribution pattern of the interface pressure and have found out the damping capacity of such layered and jointed structures both numerically and experimentally considering various parameters. Moreover, Hartwigsen et al. [17] conducted experiments to study the nonlinear effects of a typical shear lap joint on the dynamics of two

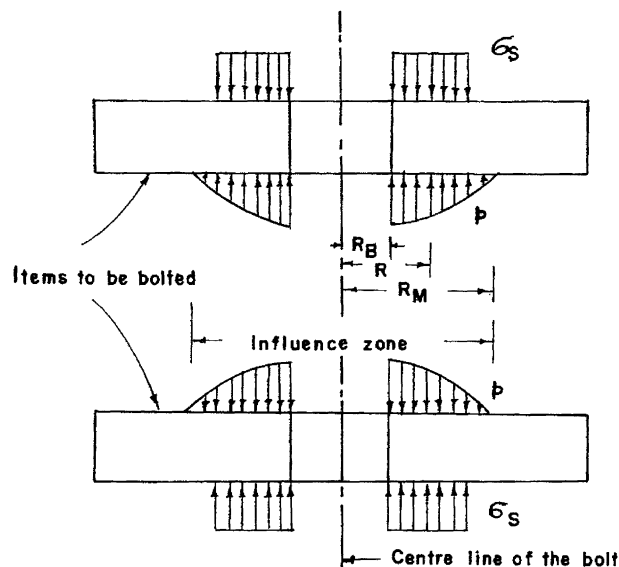

Fig. 1. Free-body diagram of a bolted joint showing the influence zone.

structures: a beam with a bolted joint in its centre; and a frame with a bolted joint in one of its members. Both structures are subjected to a variety of dynamical tests to determine the nonlinear effects of the joints. The tests reveal several important influences on the effective stiffness and damping of the lap joints. They have established that the damping is higher and amplitude-dependent in the jointed structures.

2. Theoretical analysis

As the interface pressure and its distribution pattern for layered and jointed structures have a considerable effect on its damping capacity, their accurate evaluation is essential. Gould and Mikic [11] and Ziada and Abd [12] have established that the interface pressure distribution under each connecting bolt is almost parabolic in nature as shown in Fig. 1. Hence, in the present analysis this distribution has been assumed to be polynomial with even powers in a non-dimensional form as

$$p/\sigma_s = A_1 + A_2(R/R_B)^2 + A_3(R/R_B)^4 + A_4(R/R_B)^6 + A_5(R/R_B)^8 + A_6(R/R_B)^{10}, \quad (1)$$

where p , σ_s , R and R_B are the interface pressure, surface stress on the jointed structure due to tightening load, any radius within the influencing zone and radius of the connecting bolt, respectively, and A_1 , A_2 , A_3 , A_4 , A_5 and A_6 are the constants of the polynomial. These constants are evaluated from the numerical data of Ziada and Abd [12] by using Dunn's curve fitting software. These are: $0.68517\text{E}+00$, $-0.10122\text{E}+00$, $0.94205\text{E}-02$, $-0.23895\text{E}-02$, $0.29487\text{E}-03$ and $-0.11262\text{E}-04$, respectively.

The present investigation is based on the loss energy due to friction at the interfaces and the strain energy of a cantilever beam as shown in Fig. 2. The energy loss per cycle of vibration (E_f) arising due to friction and relative dynamic slip (u_r) at the interfaces has been found out using the

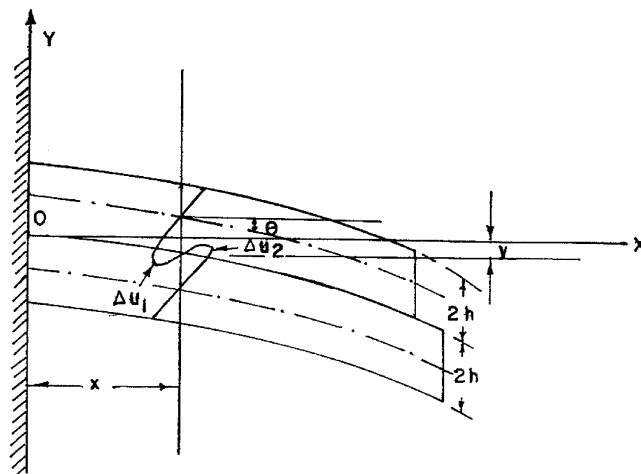

Fig. 2. Mechanism of dynamic slip at the interfaces.

theory of Nishiwaki et al. [7] as

$$E_f = \oint F_r du_r = 2F_{rM} u_{rM}, \tag{2}$$

where F_r , du_r , F_{rM} and u_{rM} are the frictional force at the interfaces of the beam in presence of relative dynamic slip, incremental relative dynamic slip, maximum frictional force at the interfaces of the beam during vibration and relative dynamic slip between the interfaces at the maximum amplitude of vibration, respectively, as shown in Fig. 3.

The maximum frictional force at the interfaces of the beam under transverse vibration is given by

$$F_{rM} = \mu N, \tag{3}$$

where μ and N are the kinematic coefficient of friction and the total normal force at the interfaces of the layers under each connecting bolt, respectively.

This total normal force has been determined by Nanda and Behera [15] and is given by

$$N = [A_1\{(R_M/R_B)^2 - 1\} + \{A_2/2\}\{(R_M/R_B)^4 - 1\} + \{A_3/3\}\{(R_M/R_B)^6 - 1\} + \{A_4/4\}\{(R_M/R_B)^8 - 1\} + \{A_5/5\}\{(R_M/R_B)^{10} - 1\} + \{A_6/6\}\{(R_M/R_B)^{12} - 1\}][P/3], \tag{4}$$

where R_M and P are the limiting radius of the influencing zone under each connecting bolt and axial load on the connecting bolt due to tightening torque, respectively.

The axial load P on the connecting bolt due to tightening torque is given by Shigley [18] as

$$P = [T/0.2D_B], \tag{5}$$

where T and D_B are the tightening torque and nominal diameter of the connecting bolt, respectively.

The vibration of the cantilever beam specimen, as shown in Fig. 2, is expressed as

$$y(x, t) = Y(x)f(t), \tag{6}$$

where the space function, $Y(x) = C_1 \sin \lambda x + C_2 \cos \lambda x + C_3 \sinh \lambda x + C_4 \cosh \lambda x$, and the time function, $f(t) = A \cos \omega_n t + B \sin \omega_n t$, C_1 , C_2 , C_3 , and C_4 are constants to be evaluated from the

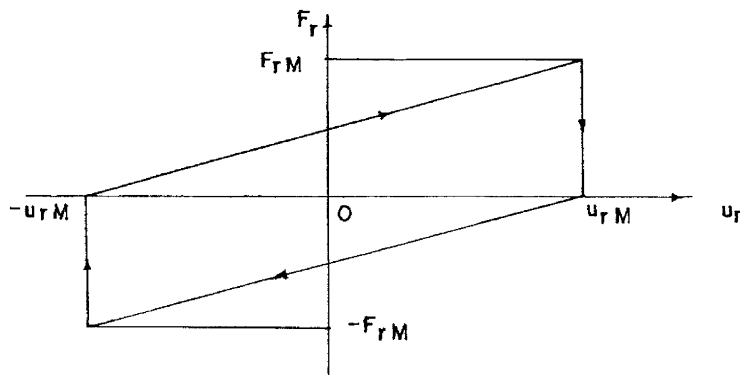

Fig. 3. Relationship between the friction force (F_r) and the relative dynamic slip (u_r) during one cycle.

boundary conditions with the usual notation: $\lambda^4 = \omega_n^2 A \gamma / EI g$ and A and B are constants to be evaluated from the initial conditions.

Using the initial free end displacement, $y(l,0)$ with its boundary conditions for the cantilever beam, the equation for slope is given by

$$[\partial y(x, t) / \partial x] = - [(\cos \lambda l + \cosh \lambda l)(\cosh \lambda x - \cos \lambda x) - (\sin \lambda l + \sinh \lambda l)(\sin \lambda x + \sinh \lambda x)] \times [\lambda y(l, 0) \cos \omega_n t] \times [2(\cos \lambda l \sinh \lambda l - \sin \lambda l \cosh \lambda l)]^{-1}, \tag{7}$$

where ω_n is the natural circular frequency of vibration.

The actual relative dynamic slip at the interfaces of a bolted joint, which is at a distance of “ l_i ” from the fixed end of a layered and jointed cantilever beam, is given by

$$u_r(l_i, t) = \alpha u(l_i, t), \tag{8}$$

where α is the dynamic slip ratio (u_r/u_0) and u_0 is the relative dynamic slip between the interfaces in the absence of a friction force at a bolted joint.

If the layered and jointed beam specimen is given an initial free end displacement, the relative dynamic slip at the interfaces of the layers, as shown in Fig. 2, is given by

$$u_r(l_i, t) = \alpha [\Delta u_1 + \Delta u_2] = 2\alpha h \tan[\partial y(l_i, t) / \partial x], \tag{9}$$

where $2h$ is the thickness of each layer of the cantilever beam.

Modifying expression (7) and combining the same with expression (9), the maximum relative dynamic slip under a connecting bolt is found to be

$$u_{rM} = [\alpha h][(\cos \lambda l + \cosh \lambda l)(\cosh \lambda l_i - \cos \lambda l_i) - (\sin \lambda l + \sinh \lambda l)(\sin \lambda l_i + \sinh \lambda l_i)] \times [\lambda y(l, 0)] \times [\sin \lambda l \cosh \lambda l - \cos \lambda l \sinh \lambda l]^{-1}. \tag{10}$$

The overall maximum relative dynamic slip for a layered and jointed cantilever beam with “ q ” number of equispaced connecting bolts having a spacing of 3.5 times their diameter has also been found out by Nanda [13] and is given by

$$u_{rM} = \alpha h X_{\text{sum}} \lambda y(l, 0), \tag{11}$$

where

$$X_{\text{sum}} = \left[(\cos \lambda l + \cosh \lambda l) \sum_{i=1}^q (\cosh \lambda l_i - \cos \lambda l_i) - (\sin \lambda l + \sinh \lambda l) \sum_{i=1}^q (\sin \lambda l_i + \sinh \lambda l_i) \right] \times [\sin \lambda l \cosh \lambda l - \cos \lambda l \sinh \lambda l]^{-1}.$$

It is assumed that the energy loss of the layered and jointed beam consists of the loss arising from interface friction under the joints (E_f) and the loss from material and support damping (E_0). Hence, the logarithmic damping decrement of a layered and jointed beam is expressed as

$$\delta = [(E_f/E_n) + (E_0/E_n)]/2 = \delta_f + \delta_0, \tag{12}$$

where E_n is the energy stored per cycle of vibration due to the initial amplitude of excitation $[y(l,0)]$ and is given by $E_n = [ky^2(l,0)]/2$.

The logarithmic damping decrement due to material and support damping (δ_0) being very small compared to the interface friction damping, is neglected and the expression for the logarithmic damping decrement is simplified as

$$\delta \approx \delta_f = E_f/2E_n. \quad (13)$$

The energy loss per cycle due to the friction at the interfaces as given in expression (2), is modified by combining expressions (3) and (11) and hence, the logarithmic damping decrement for such a beam is then found to be

$$\delta = E_f/2E_n = 2\mu N\alpha h X_{\text{sum}} \lambda/ky(l, 0), \quad (14)$$

where k is the static bending stiffness of the layered and jointed cantilever beam.

As expression (14) for logarithmic damping decrement is valid for a two-layered and jointed cantilever beam, a generalized expression has been developed for a multi-layered and jointed cantilever beam as given by

$$\delta = 2(m - 1)\mu N\alpha h X_{\text{sum}} \lambda/ky(l, 0), \quad (15)$$

where m is the number of layers.

The logarithmic damping decrement for two as well as multi-layered structures jointed with connecting bolts with varying diameter can be found out using expressions (14) and (15), respectively. The dynamic slip ratios as found out by Nanda [13] and kinematic coefficient of friction as used by Masuko et al. [5] have been utilized in these expressions to find out the numerical values of logarithmic damping decrement. However, product of dynamic slip ratios and kinematic coefficient of friction as found out by Nanda [13] has been used for aluminium specimens to find out the numerical values of logarithmic damping decrement.

The variation of the interface pressure distribution plays a vital role on the logarithmic damping decrement of layered and jointed structures and the same effect has been studied experimentally by using washers on both the sides of the specimens. The numerical results for the logarithmic damping decrement have been found out using the values of dynamic slip ratios determined by Nanda [13]. These values of the dynamic slip ratios have been changed due to variation in the interface pressure with use of washers on both the sides of the specimens.

3. Experimental techniques and experiments

In order to find out the logarithmic damping decrement of layered and jointed beams and to compare it with the numerical results evaluated from analytical expressions, an experimental set-up with a number of specimens has been fabricated. The experimental set-up with detailed instrumentation is shown in Fig. 4. The specimens are prepared from commercial mild steel and aluminium flats of the sizes as presented in Table 1 by joining two as well as more number in layers with the help of equispaced connecting bolts of same tightening torque on them. The distance between the consecutive connecting bolts have been kept as 3.5 times their diameter depending on the diameter of the connecting bolts. The width of the specimens has also been changed according to the zone of influence. The cantilever lengths of the specimens have been varied accordingly in order to accommodate the corresponding number of connecting bolts as presented in Table 1.

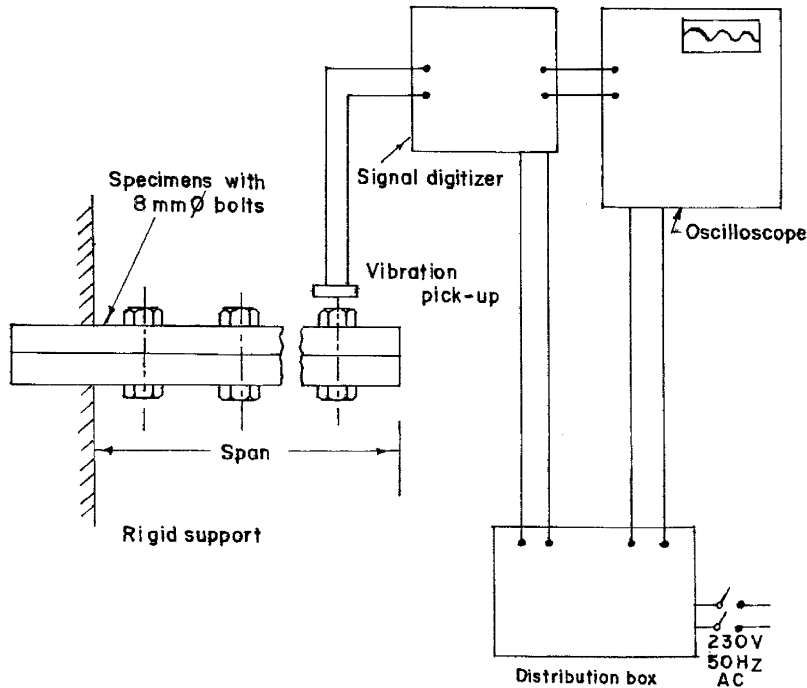

Fig. 4. Schematic diagram of experimental set-up with detailed instrumentation.

The specimens are rigidly fixed to the support to obtain perfect cantilever condition and experiments are conducted initially to determine the bending modulus of elasticity (E) of the specimen materials. Solid cantilever specimens out of the same stock of commercial mild steel and aluminium flats are held rigidly at the fixed end and its free end deflection (Δ) is measured by applying static loads (W). From these static loads and corresponding deflections, average static bending stiffness (W/Δ) is determined. The bending modulus for the specimen material is then evaluated from the expression $E = [(W/\Delta)(l^3/3I)]$. The average values of “ E ” for the mild steel and aluminium specimens used in the experiments are found to be 172.7 and 63.30 GN/m², respectively.

The static bending stiffness (k) of the specimens are determined and is found that the same for layered and jointed beam is always less than that of an equivalent solid one (k') and increases with increase in tightening torque on the connecting bolts and remains almost constant after a limiting value, i.e., 10.370 N m (7.5 lb ft) as shown in Fig. 5 for a particular case. The ratio of this bending stiffness at the limiting tightening torque condition with the equivalent bending stiffness of a solid one (α') are found out for all specimens. The average value of α' for each group of specimens has been utilized in the numerical analysis.

The logarithmic damping decrement and natural frequency of vibration of all the specimens at their first mode of free vibration are found out experimentally. The tightening torques on all the connecting bolts of the specimens are maintained equal for each set of observations and varied in steps in most of the cases as 3.46, 6.92, 13.84, 20.76, and 27.68 N m (i.e., 2.50, 5.00, 10.00, 15.00 and 20.00 lb ft respectively). The lengths of these specimens during experimentation are also

Table 1
Details of the specimens used in the experiment both with and without washers

Dimension of the specimen (thickness × width), (mm × mm)	Material of the specimen	Diameter of the connecting bolt (mm)	Number of layers used	Number of bolts used	Cantilever length (mm)
3.00 × 42.00	Mild steel	12	2	9	378.00
5.40 × 41.00				8	336.00
12.40 × 40.00				7	294.00
6.80 × 24.50	Mild steel	8	2	14	392.00
11.40 × 25.00				13	364.00
				12	336.00
6.80 × 21.00	Mild steel	6	2	11	308.00
11.40 × 21.00				18	378.00
				17	357.00
11.40 × 21.00				16	336.00
	15	315.00			
3.20 × 42.00	Aluminium	12	2	9	378.00
5.60 × 41.00				8	336.00
11.40 × 37.20				7	294.00
5.60 × 28.00	Aluminium	8	2	14	392.00
11.40 × 27.00				13	364.00
				12	336.00
5.60 × 21.00	Aluminium	6	2	11	308.00
11.40 × 21.00				18	378.00
				17	357.00
11.40 × 21.00				16	336.00
	15	315.00			
11.20 × 21.00	Aluminium	6	4	18	378.00
11.20 × 21.00	Solid aluminium beam				378.00

varied. In order to excite the specimens at their free ends, a spring loaded exciter was used. The dial gauge incorporated with the exciter recorded the initial amplitude of excitation. The amplitude of excitation was varied in steps and maintained as 0.1, 0.2, 0.3, 0.4, and 0.5 mm for all the specimens tested under the different conditions of the tightening torque on the connecting bolts. The free vibration at the required amplitude of excitation was sensed with a non-contacting type of vibration pick-up and the corresponding signal was fed to a cathode ray oscilloscope through a digitizer to obtain a steady signal. The logarithmic damping decrement was then evaluated from the measured values of the amplitudes of the first cycle (a_1), last cycle (a_{n+1}) and the number of cycles (n) of the steady signal by using the equation $\delta = \ln(a_1/a_{n+1})/n$. The logarithmic damping decrement found out using the above technique does not address the change of damping in one signal as amplitude decays and the results so obtained may be seen as the

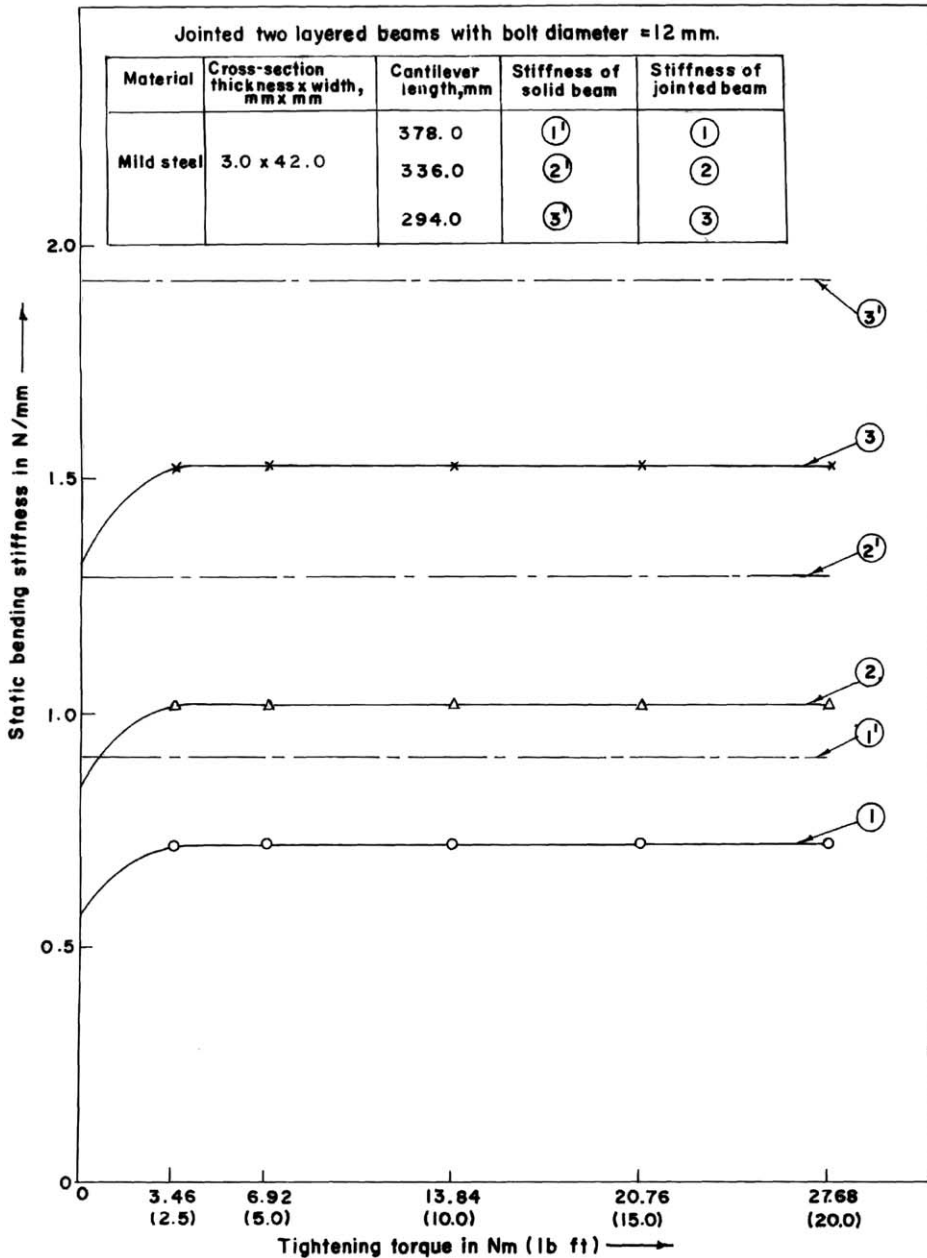

Fig. 5. Variation of static bending stiffness with applied tightening torque on the connecting bolts.

variation in “overall equivalent” damping of structure with the variation of initial amplitude of excitation. The corresponding natural frequency was also determined from the time period (T_1) of the signal by using the relationship $f = 1/T_1$. It is found that the natural frequency of vibration of the specimens are always less than that of their equivalent solid ones and increases with increase

in tightening torque on the connecting bolts and remains constant after a limiting value, i.e., 10.370 N m (7.5 lb ft). The natural frequency of vibration increases with increase in tightening torque due to higher static bending stiffness as evident from the relationship, $f = \sqrt{(k/m')}$, where k and m' are the static bending stiffness and mass of the beam respectively.

4. Comparison of experimental and numerical results

The logarithmic damping decrements of two layered mild steel and aluminium cantilever specimens with diameters 6, 8 and 12 mm connecting bolts have been found out using expression (14). These numerical results have been determined along with the corresponding experimental ones for comparison and one such result from each has been shown in Figs. 6–12. It is observed that both the curves are very close to each other with a maximum variation of 1.43% which authenticates the accuracy of the theory developed.

Further, numerical results for two layered and jointed cantilever beams with washers on both the sides of the specimens with 6, 8 and 12 mm diameter connecting bolts have been found out using the above expression in order to find out its effect on the damping capacity of layered and jointed structures. These numerical results have been plotted along with the corresponding experimental ones and one such example from each has been shown in Figs. 13–18 showing that both the plots are very close to each other with a maximum variation of 1.83%.

Moreover, in order to study the effect of number of layers on the damping capacity of layered and jointed structures, numerical results for multi-layered and jointed aluminium specimens with 6 mm diameter connecting bolts and washers have been determined using expression (15). These numerical results for logarithmic damping decrement are also presented along with the corresponding experimental ones as shown in Fig. 19 which shows that both the curves are very close to each other with a maximum variation of 1.12%.

5. Discussion and conclusion

From the theoretical analysis as well as numerical and experimental results, the following salient points have been observed. They are discussed below and the conclusions have been drawn accordingly.

- (1) The static bending stiffness of the layered and jointed structure is smaller than that of an equivalent solid one and increases with an increase in the tightening torque on the connecting bolts and remains almost constant beyond a limiting value of the tightening torque, i.e., 10.370 N m (7.50 lb ft). Moreover, this stiffness increases with a decrease in diameter of the connecting bolts when the dimensions of the layered and jointed structures are kept constant. However, the static bending stiffness decreases with a decrease in diameter when the sizes of such structures are changed according to the zone of influence due to tightening which is equal to 3.5 times the diameter of the connecting bolts. In such cases, the width of the specimen reduces, thereby decreasing the second moment of inertia (I) and also the static bending stiffness.

- (2) The natural frequency of first mode vibration of layered and jointed structure is found to be smaller than that of its equivalent solid one and increases with an increase in the tightening torque on the connecting bolts due to higher static bending stiffness. The static bending stiffness increases because of higher interface pressure due to tightening torque. However, the frequency remains constant beyond a limiting value of the tightening torque, i.e., 10.370 N m (7.50 lb ft).

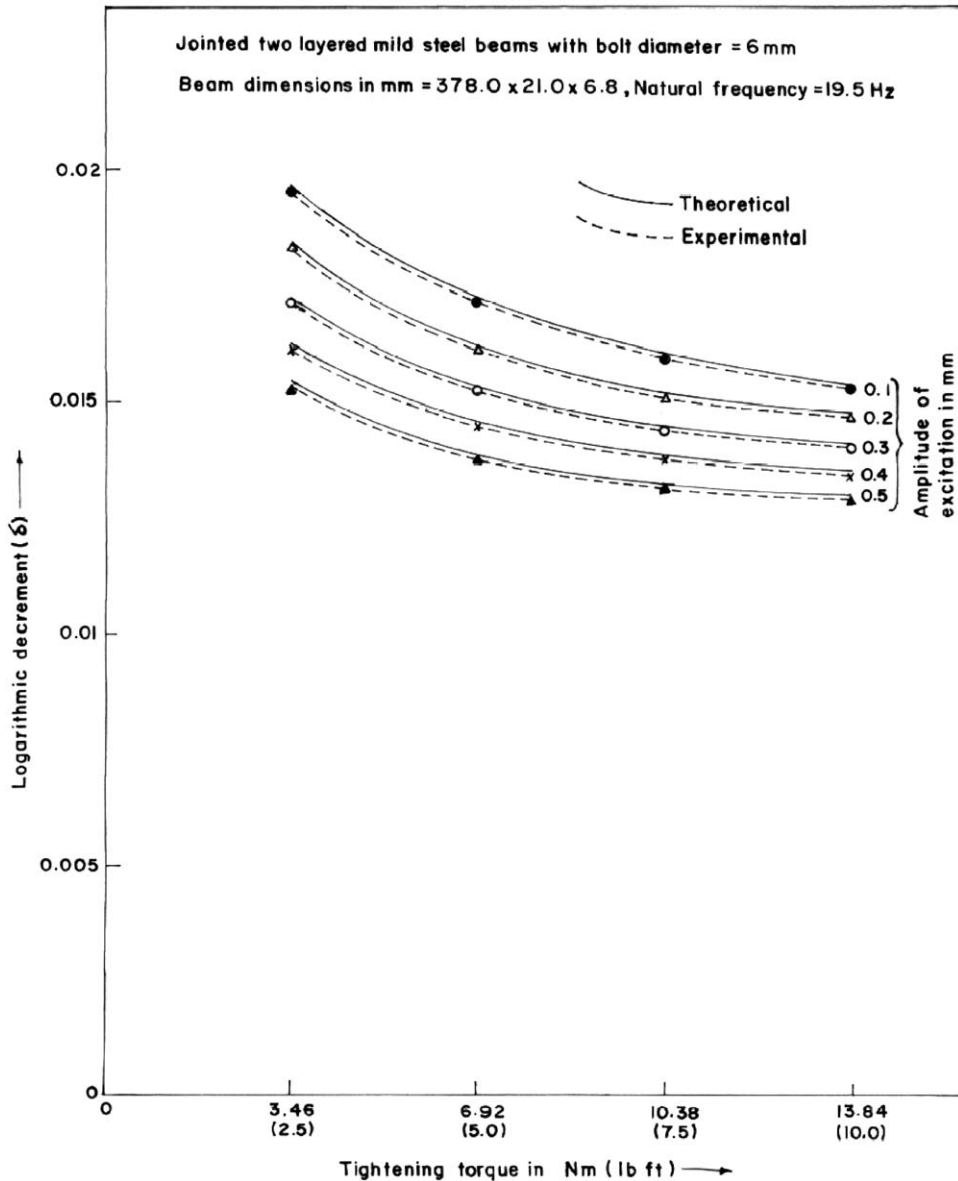

Fig. 6. Variation of logarithmic decrement (δ) with applied tightening torque on the connecting bolts.

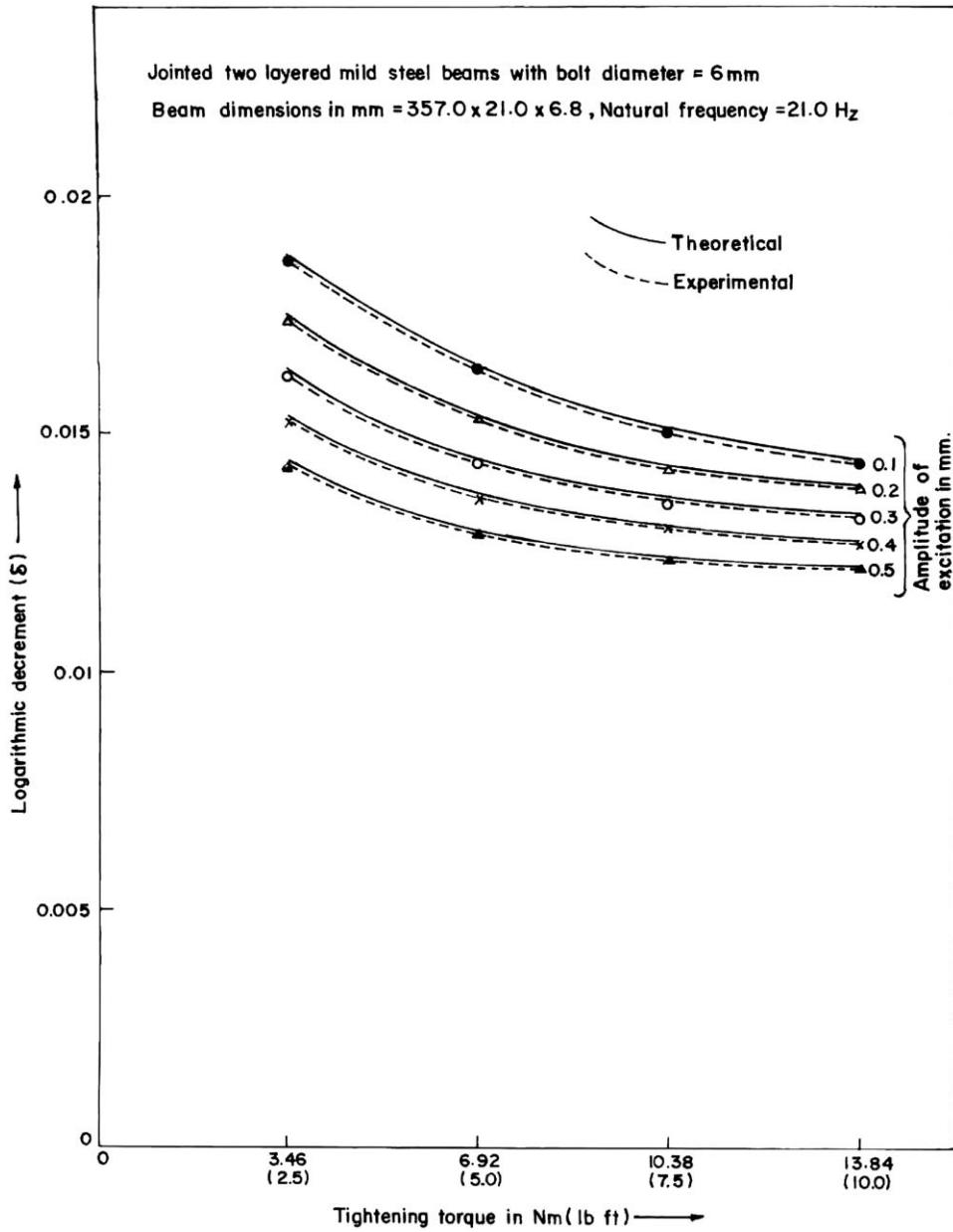

Fig. 7. Variation of logarithmic decrement (δ) with applied tightening torque on the connecting bolts.

- (3) The mechanism of damping in layered and jointed structures assumed in the present analysis has been proved to be authentic, since the results for the logarithmic damping decrement obtained both from the numerical analysis and experiments tally reasonably well within 1.43%.

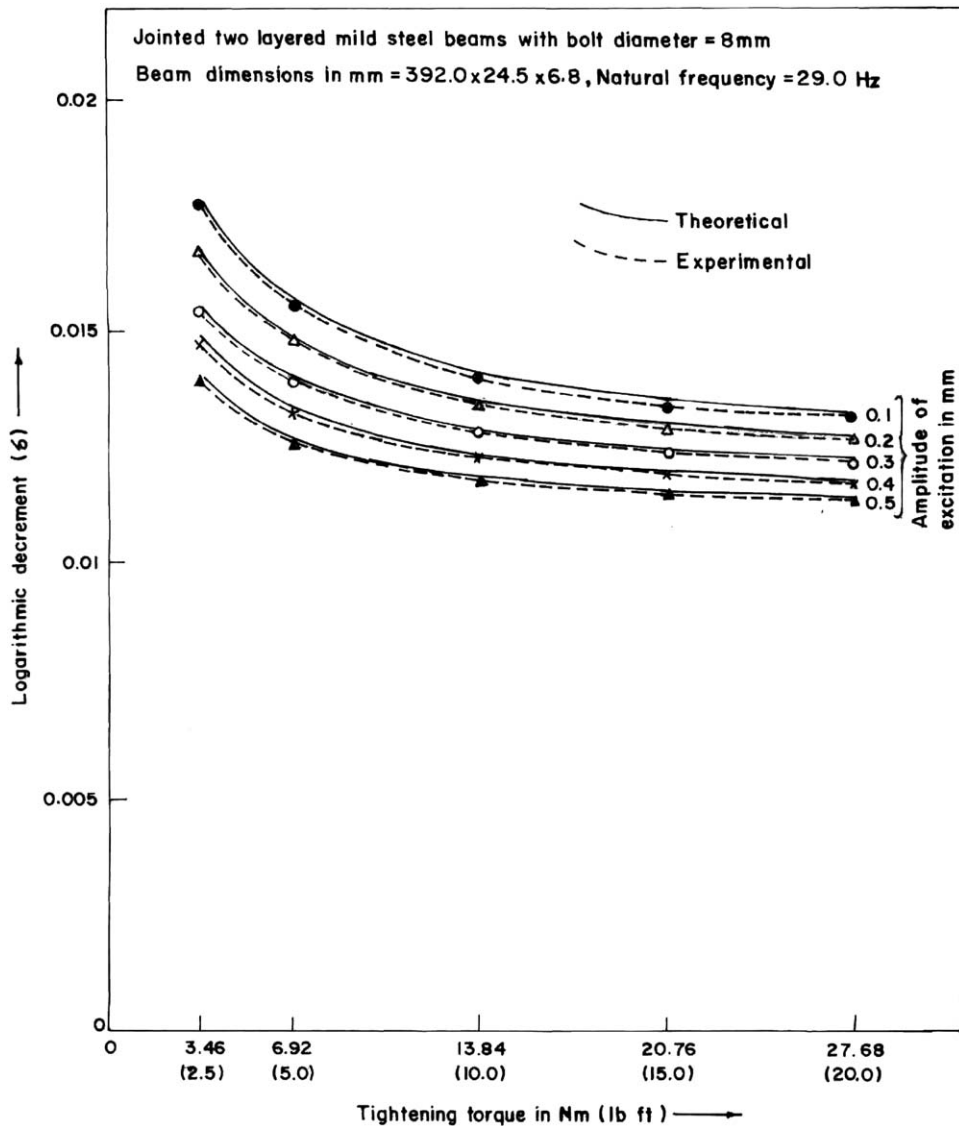

Fig. 8. Variation of logarithmic decrement (δ) with applied tightening torque on the connecting bolts.

- (4) The following influencing parameters play a major role on the damping capacity of layered structures jointed with connecting bolts. They are: (a) tightening torque on the connecting bolts, (b) number of layers, (c) amplitude of excitation, (d) frequency of excitation, (e) diameter of the connecting bolts and (f) washers.

(a) It has been established by Masuko et al. [5] that the logarithmic damping decrement increases along with an increase in the tightening torque on the connecting bolts and

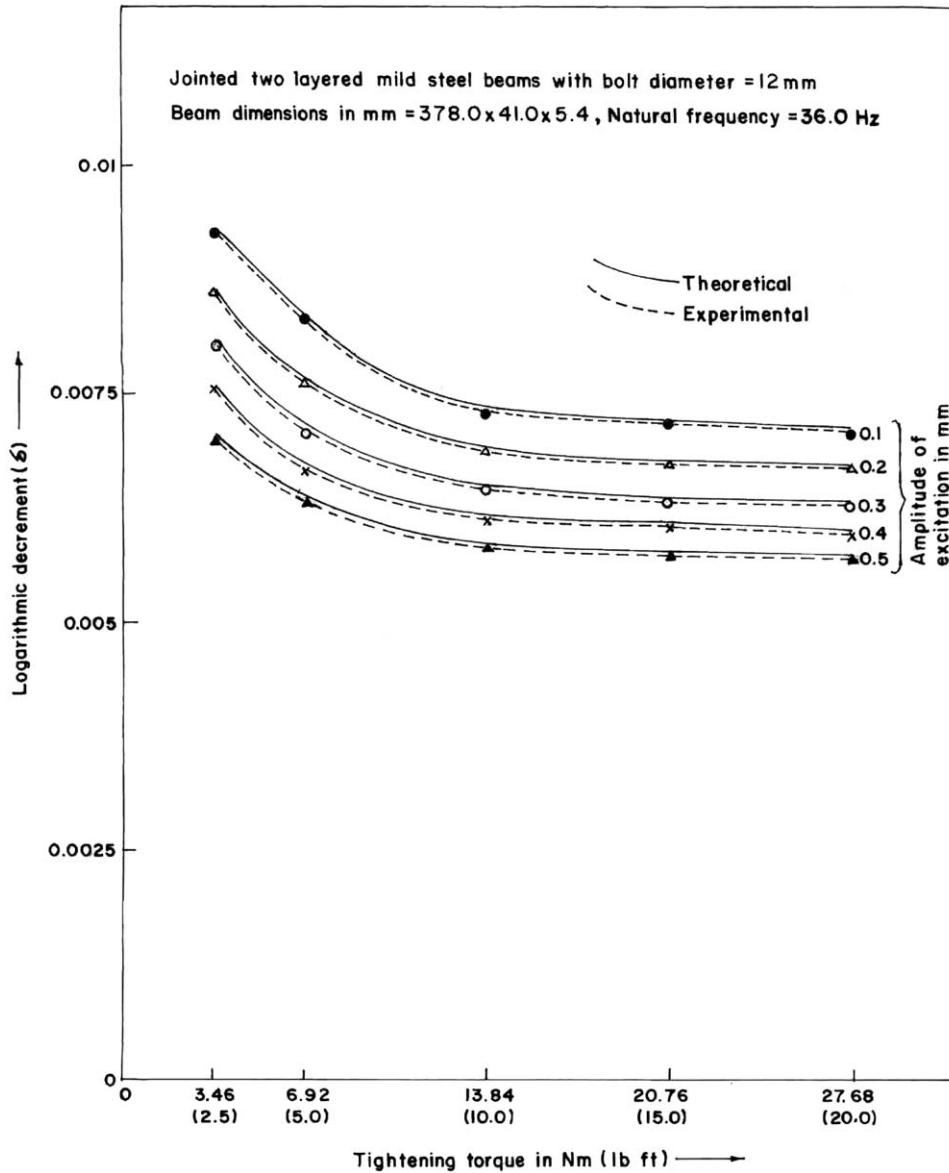

Fig. 9. Variation of logarithmic decrement (δ) with applied tightening torque on the connecting bolts.

reaches a peak at a particular tightening torque and then reduces with an increase in the tightening torque on the connecting bolts. This is due to higher interface pressure with lower dynamic slip ratio at the interfaces which tend to behave like a solid beam. However, the limiting tightening torque at which the logarithmic decrement becomes a maximum, is so small that it is not practically possible to determine it in real application.

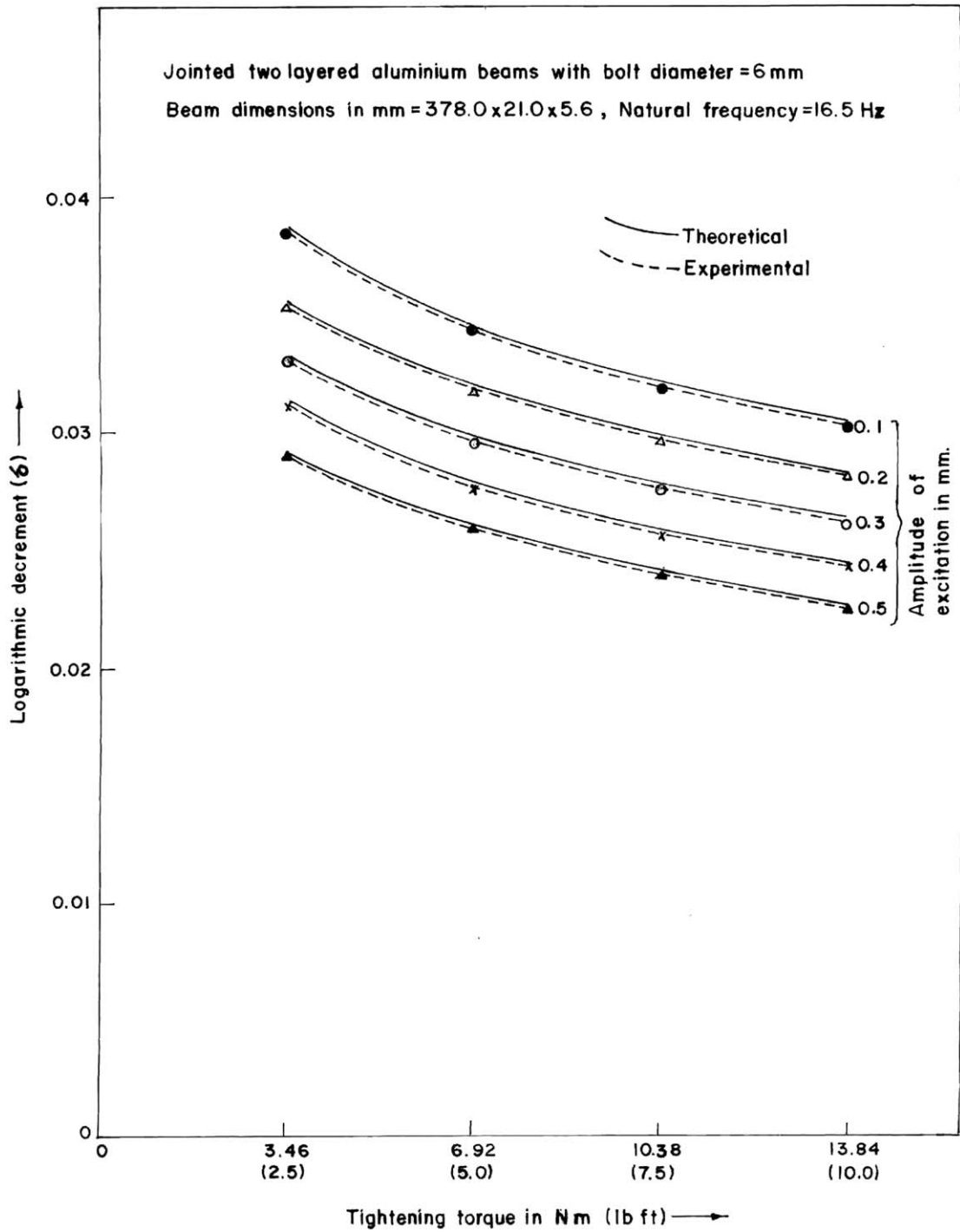

Fig. 10. Variation of logarithmic decrement (δ) with applied tightening torque on the connecting bolts.

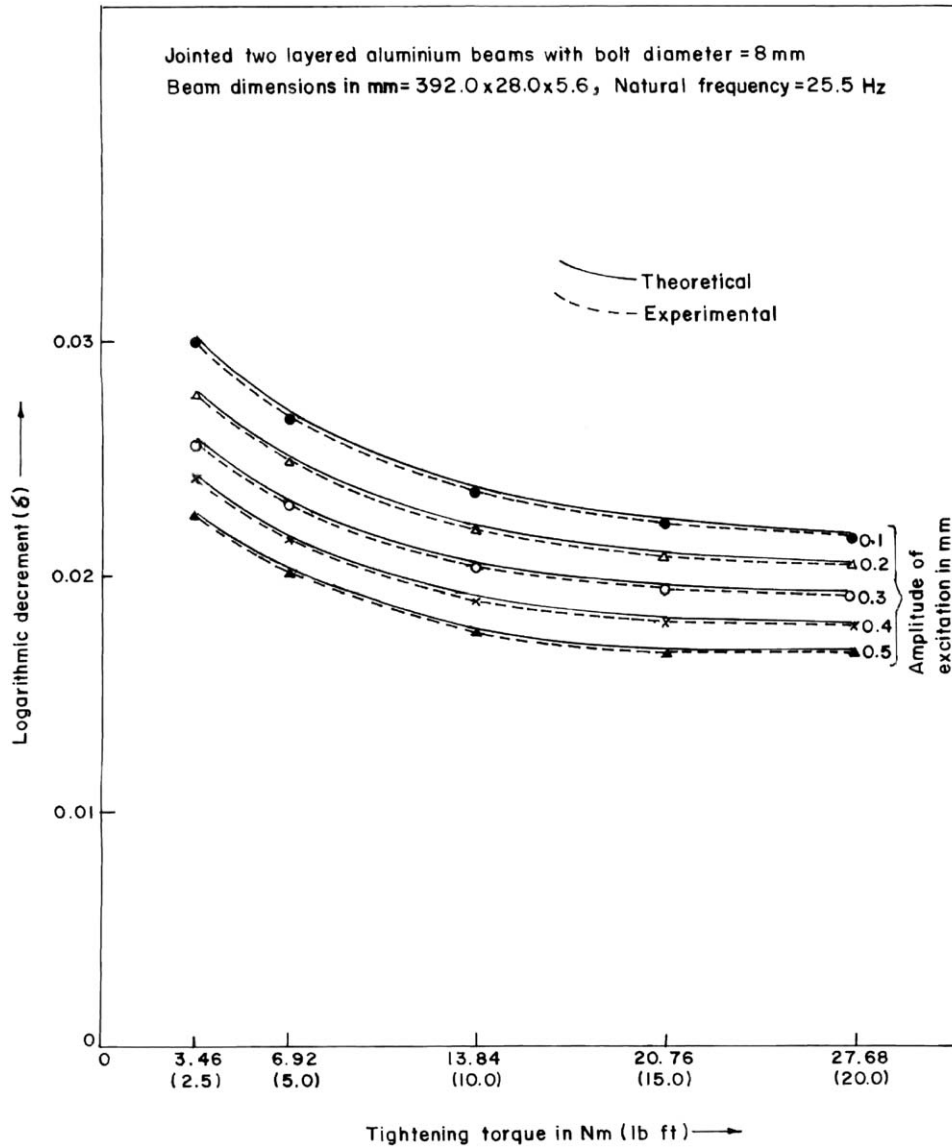

Fig. 11. Variation of logarithmic decrement (δ) with applied tightening torque on the connecting bolts.

- (b) The logarithmic damping decrement increases with an increase in the number of layers in a layered and jointed structure due to an increase in the interface friction layers which causes an increase in the energy loss due to interface friction.
- (c) The logarithmic damping decrement of a layered and jointed structure decreases with an increase in amplitude of excitation due to introduction of higher energy into the system compared to that of the dissipated energy due to interface friction. Although, the dynamic

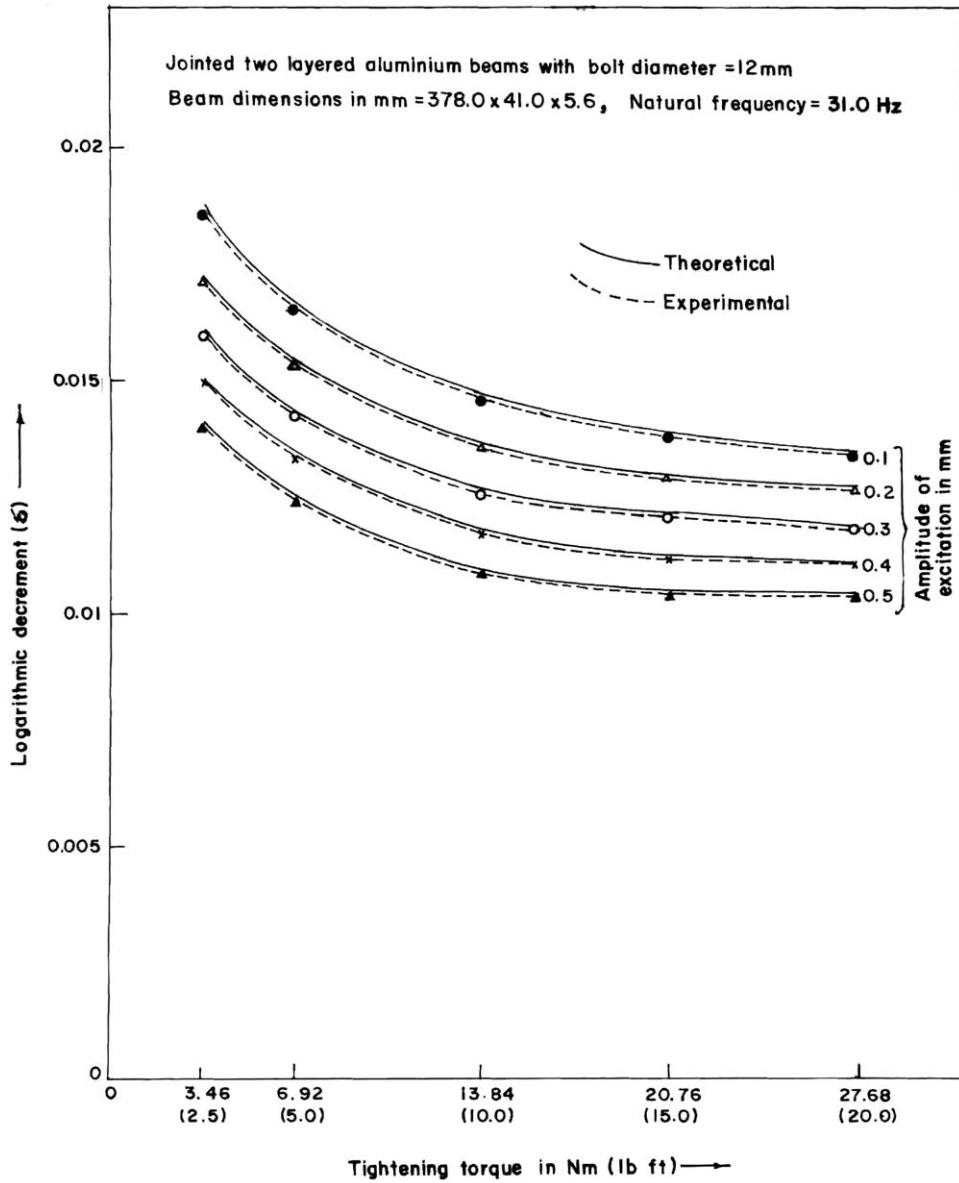

Fig. 12. Variation of logarithmic decrement (δ) with applied tightening torque on the connecting bolts.

slip ratio increases with an increase in amplitude of excitation, but the energy introduced in to the system is more compared to the increase in dissipated energy due to interface friction and the net effect is a decrease in the logarithmic damping decrement.

- (d) The logarithmic damping decrement of a layered and jointed structure decreases with an increase in natural frequency of vibration. Although, the dynamic slip ratio increases due

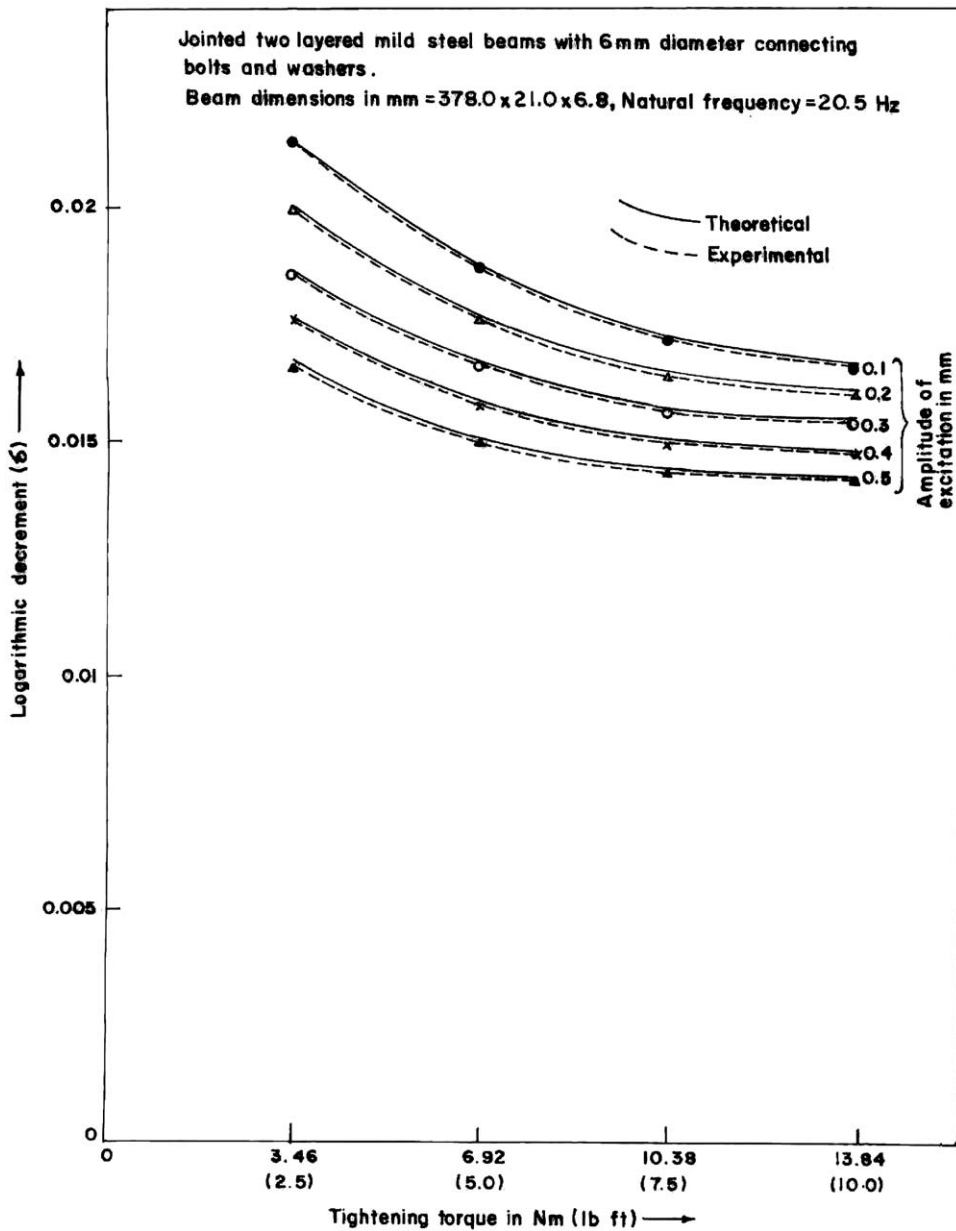

Fig. 13. Variation of logarithmic decrement (δ) with applied tightening torque on the connecting bolts.

to increase in the natural frequency of vibration but the increase in static bending stiffness of the layered and jointed structure is more compared to the loss energy due to friction at the interfaces resulting in the decrease of the logarithmic damping decrement. Moreover, the static bending stiffness and the natural frequency of vibration of the layered and

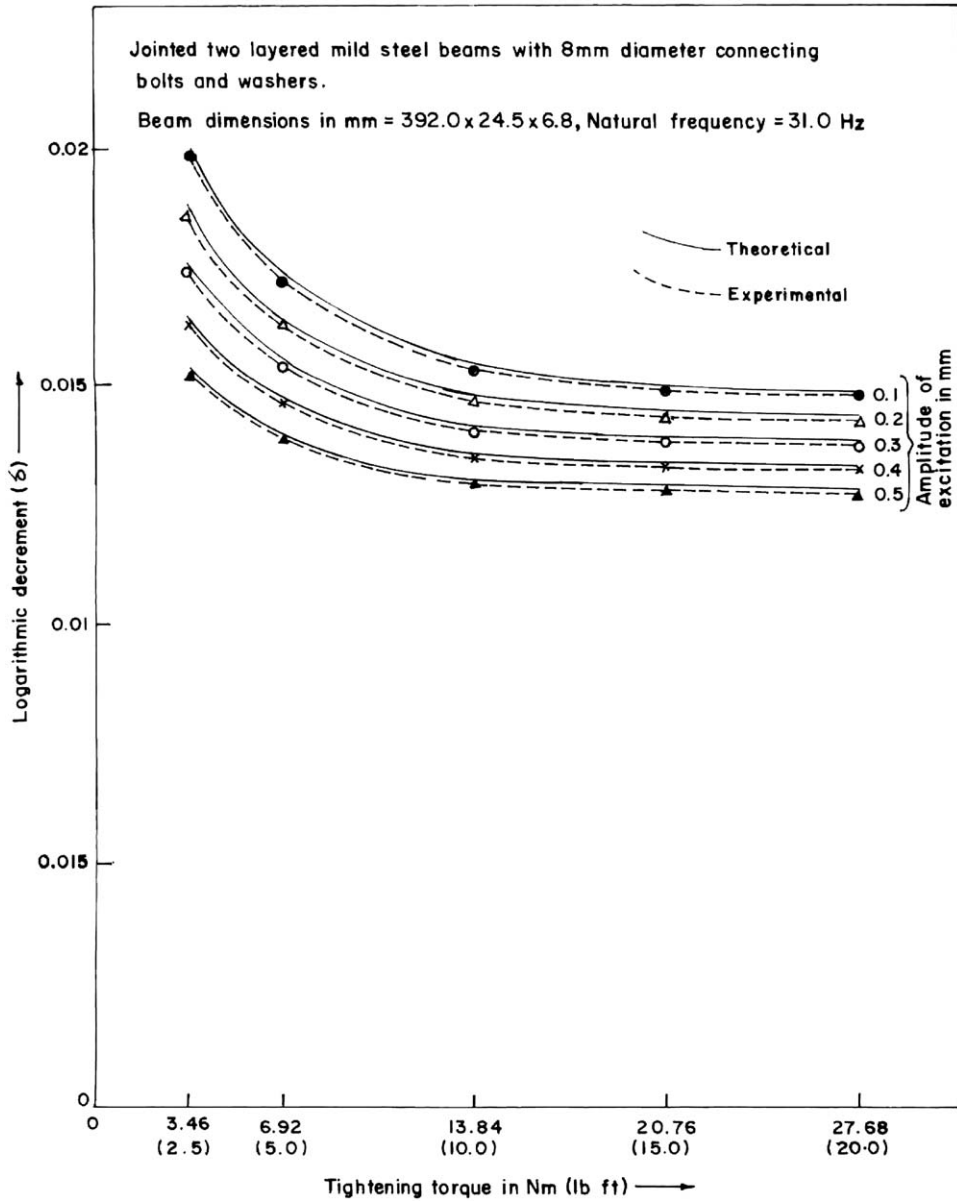

Fig. 14. Variation of logarithmic decrement (δ) with applied tightening torque on the connecting bolts.

jointed structures increase with the increase in the cross-section and decrease in the cantilever length of the specimens.

- (e) The damping capacity of a layered and jointed structure increases as the diameter of the connecting bolts decreases. The axial load on the connecting bolts increases for the same tightening torque due to decrease in diameter and thereby increases the interface pressure

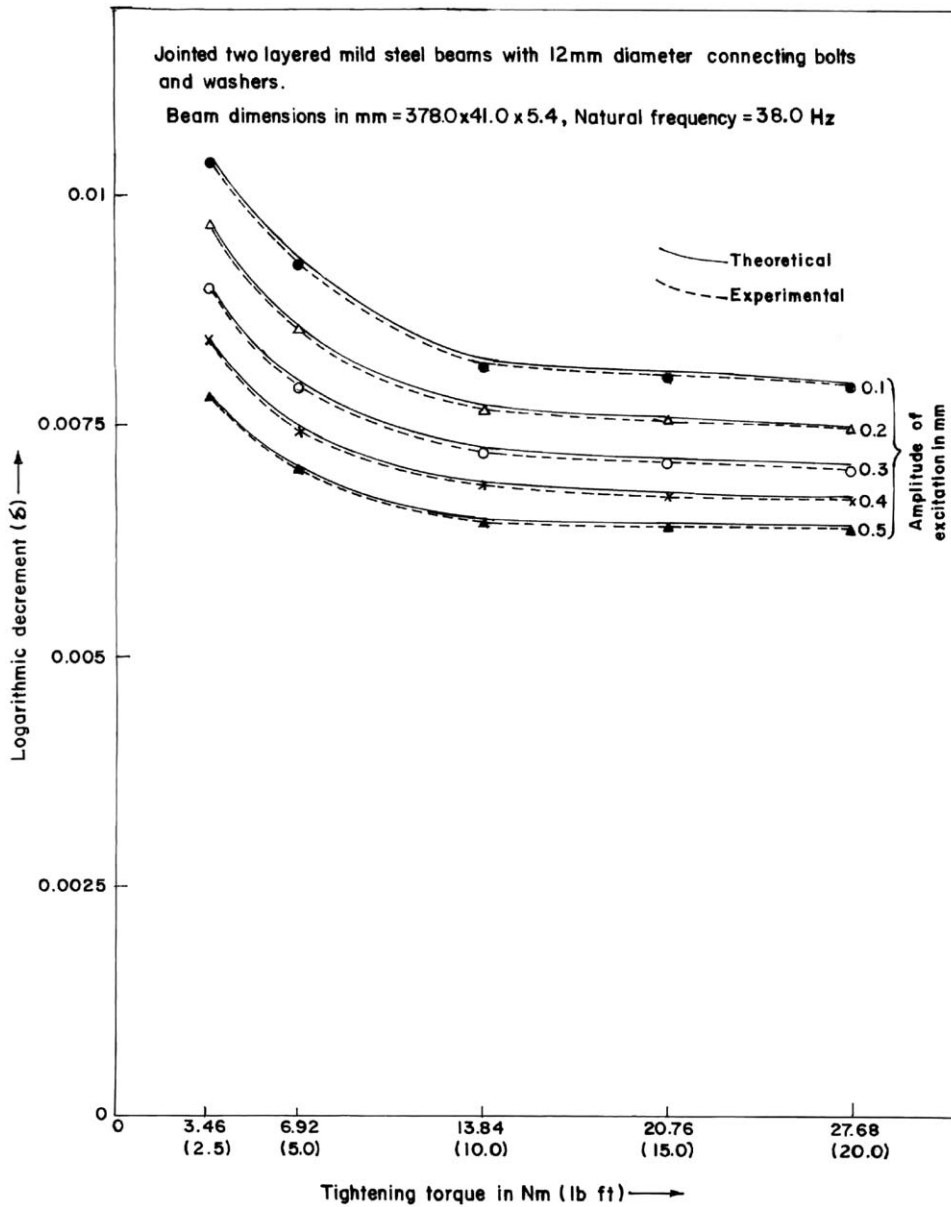

Fig. 15. Variation of logarithmic decrement (δ) with applied tightening torque on the connecting bolts.

as well as the frictional force and also the loss energy at the interfaces due to increase in the total normal force as evident from Eqs. (4), (5) and (14) and (15). The static bending stiffness decreases thereby decreasing the dynamic slip ratio and the net effect is an increase in logarithmic damping decrement of the layered and jointed structures. The static bending stiffness of the layered and jointed specimens decreases due to decrease in the

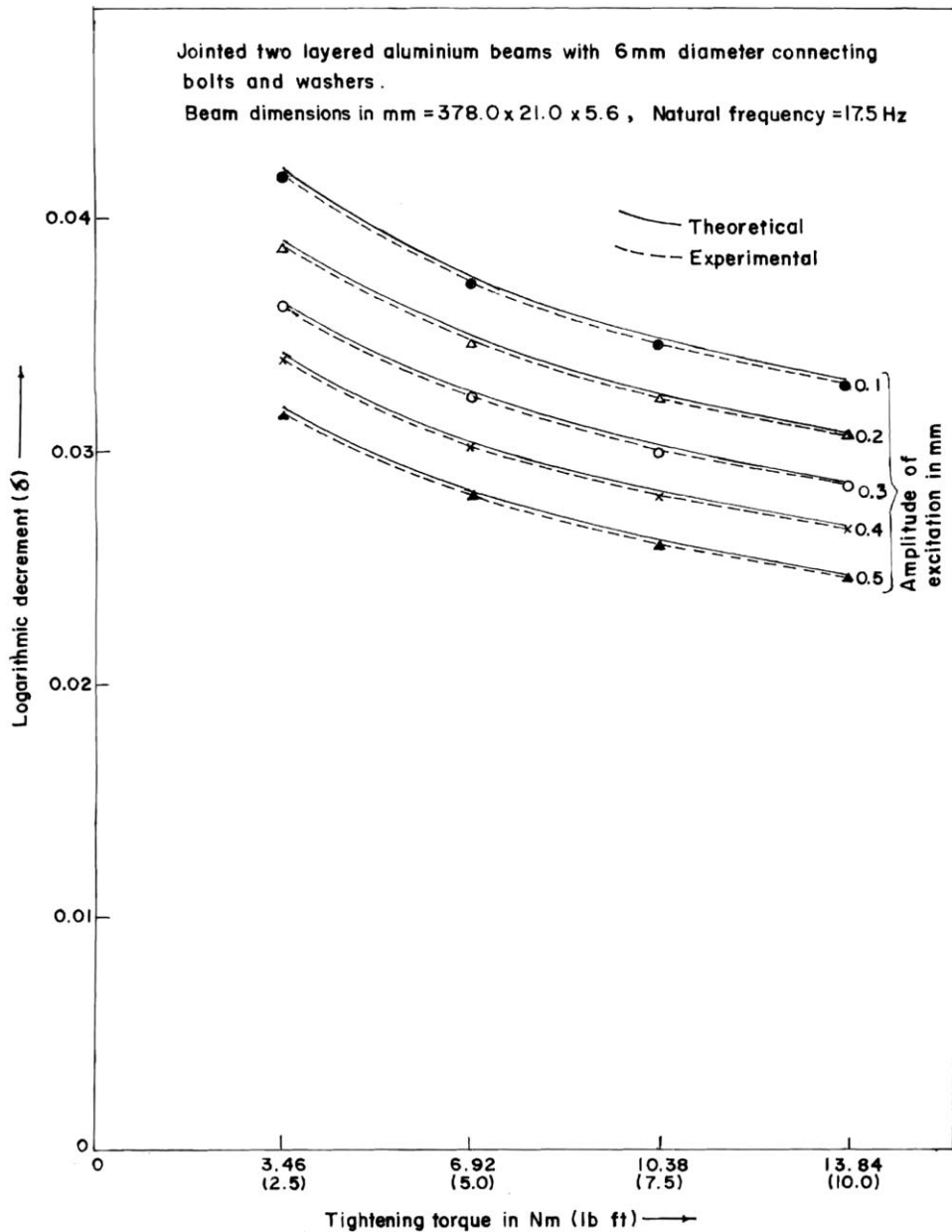

Fig. 16. Variation of logarithmic decrement (δ) with applied tightening torque on the connecting bolts.

width of the specimens which decreases the second moment of inertia (I) and hence the static bending stiffness ($3EI/l^3$). The width of the specimens change according to the zone of influence due to tightening which is equal to 3.5 times the diameter of the connecting bolts.

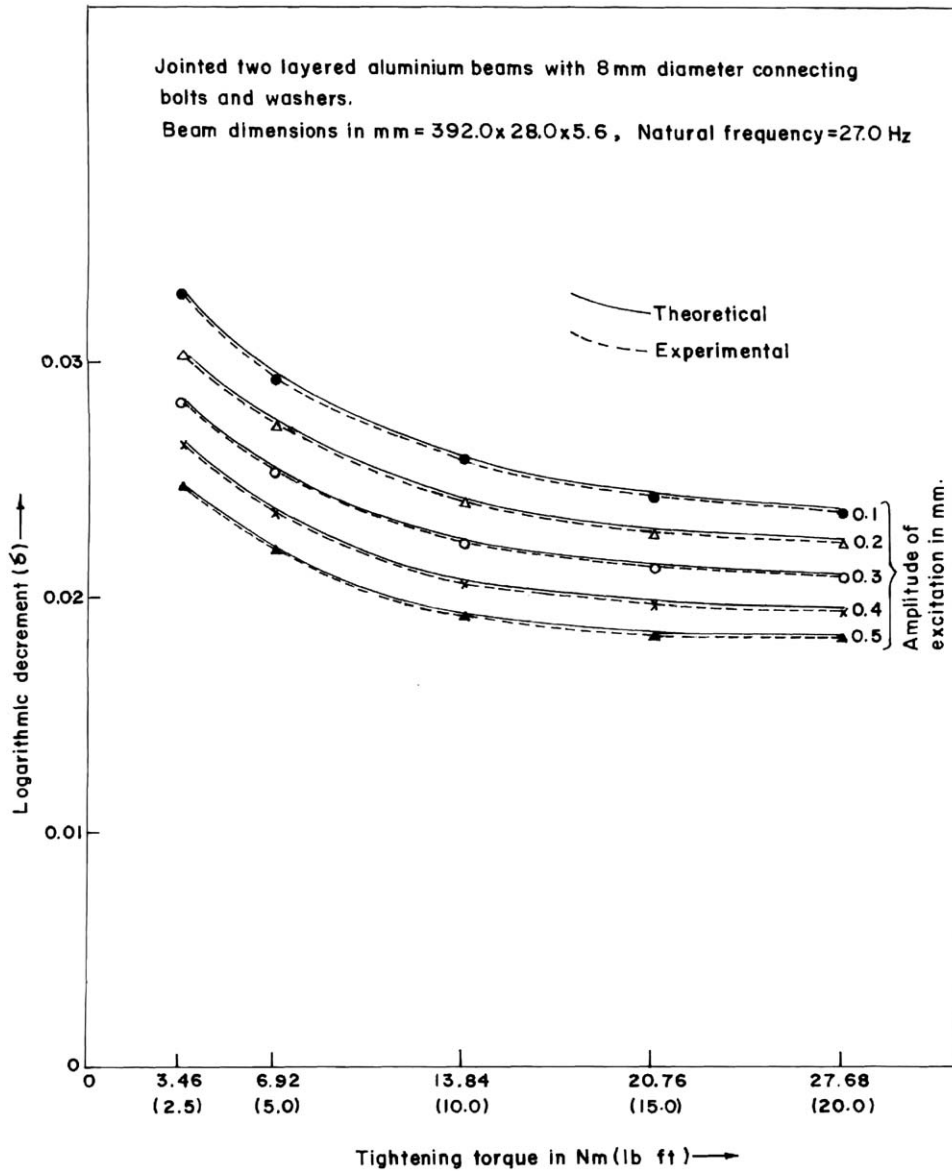

Fig. 17. Variation of logarithmic decrement (δ) with applied tightening torque on the connecting bolts.

(f) It has been observed from both the numerical and experimental results that the logarithmic damping decrement of a layered and jointed structure connected with bolts and washers on both sides are more compared to that of structures without washers. The reasons attributed for the above findings are as follows. The static bending stiffness for such cases increases thereby increasing the dynamic slip ratio. Although, the layered and

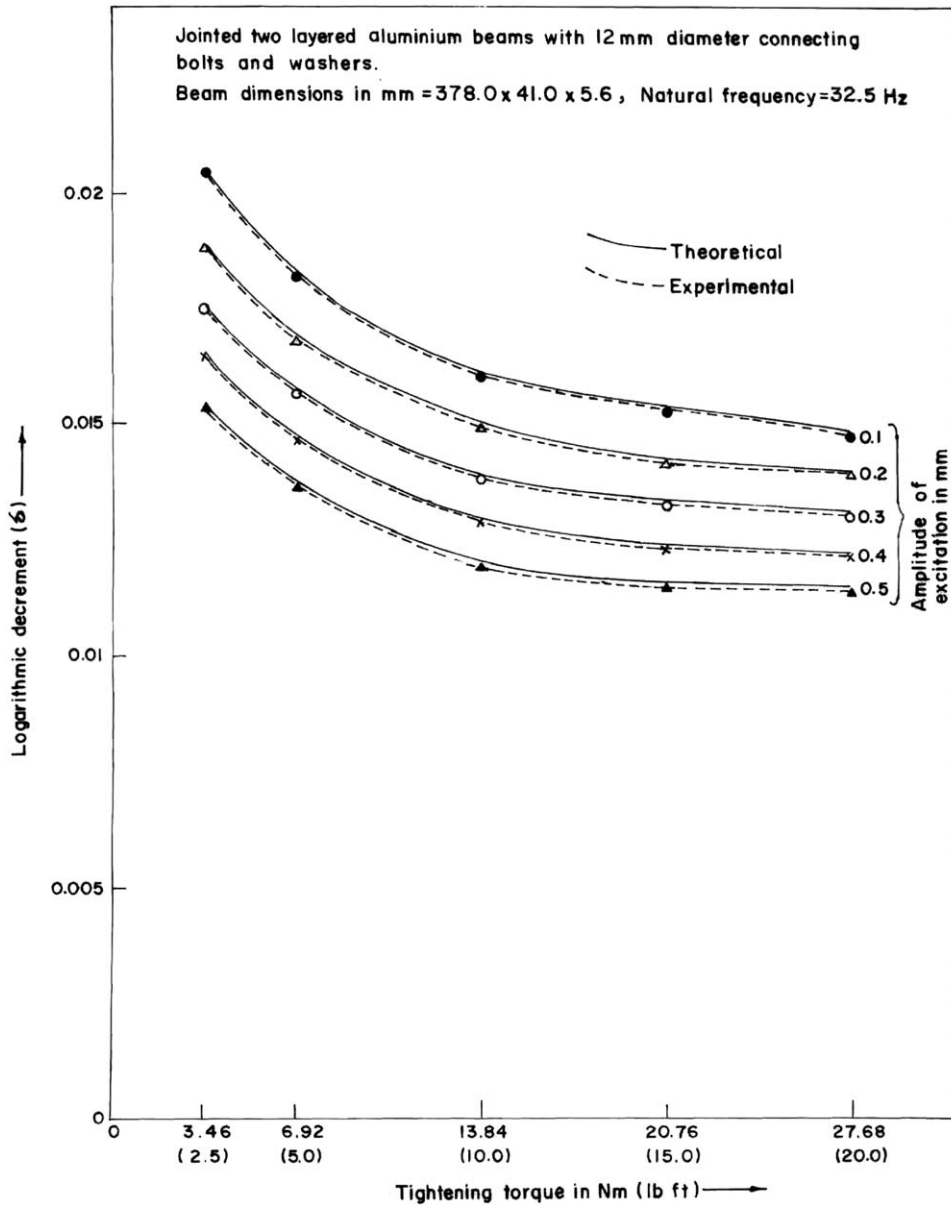

Fig. 18. Variation of logarithmic decrement (δ) with applied tightening torque on the connecting bolts.

jointed structure shows higher stiffness with the use of washers, the energy loss due to higher dynamic slip ratio as well as modified interface pressure distribution increases at a higher rate than that of the strain energy due to higher stiffness.

Finally, it is established that the damping capacity of the layered and jointed structures can be improved considerably by increasing the number of layers, using connecting bolts of smaller

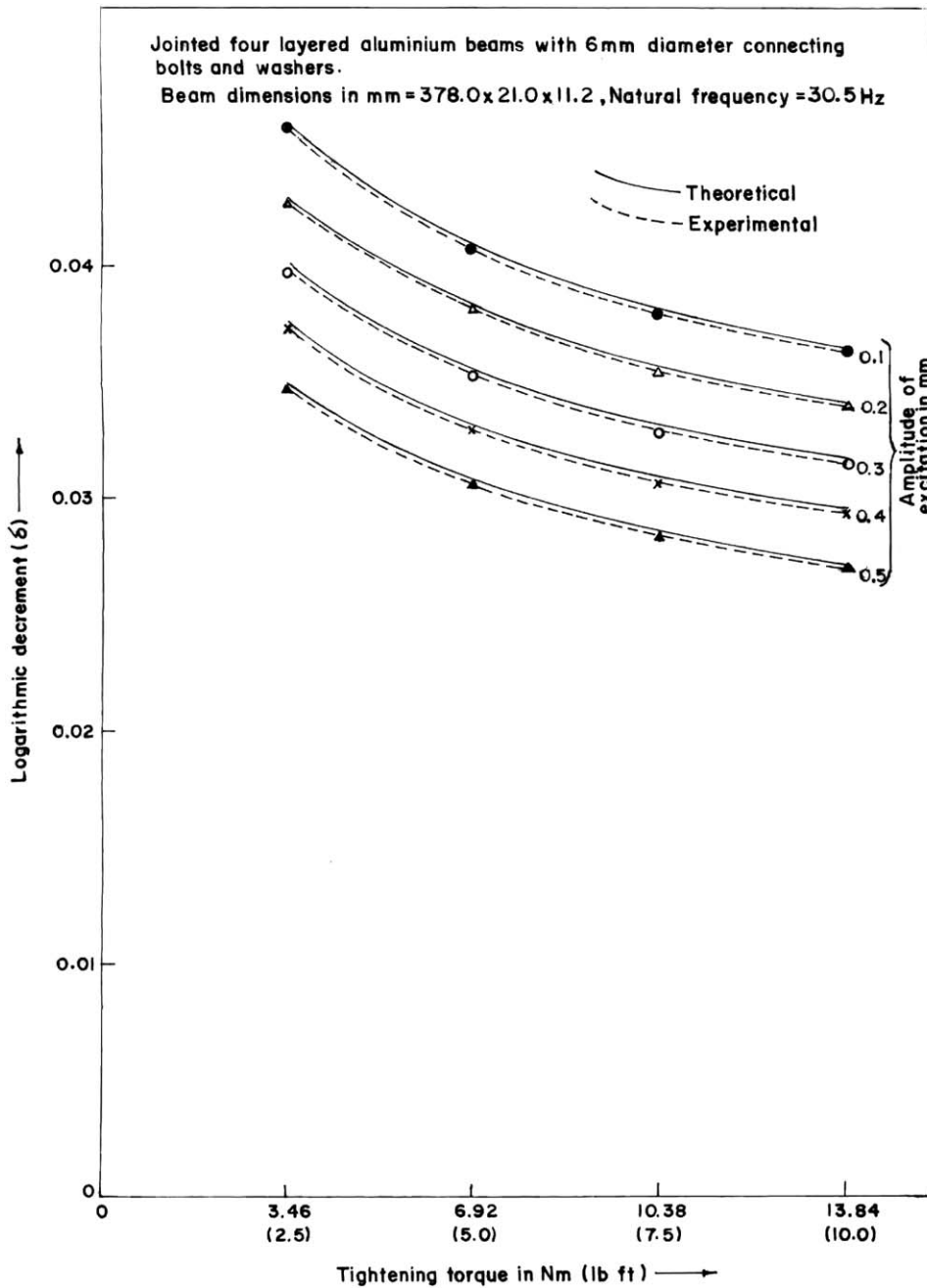

Fig. 19. Variation of logarithmic decrement (δ) with applied tightening torque on the connecting bolts.

diameter with washers on both the sides as well as with minimum possible tightening torque on the connecting bolts. This increase in logarithmic damping decrement may go even up to 655.7% in case of aluminium specimens compared to that of an equivalent solid beam.

References

- [1] I. Fernlund, A method to calculate the pressure between bolted or riveted plates, *Transactions of Chalmers University Technology* 245 (1961), Gothenberg, Sweden.
- [2] T. Kobayashi, T. Matsubayashi, Considerations on the improvement of the stiffness of bolted joints in machine tools, *Bulletin of JSME* 29 (1986) 3934–3937.
- [3] T. Kobayashi, T. Matsubayashi, Considerations on the improvement of the stiffness of bolted joints in machine tools, *Transactions of the Japan Society of Mechanical Engineering* 52 (1986) 1092–1096.
- [4] Y.S. Shin, J.C. Iverson, K.S. Kim, Experimental studies on damping characteristics of bolted joints for plates and shells, *Transactions of ASME, Journal of Pressure Vessel Technology* 113 (1991) 402–408.
- [5] M. Masuko, Y. Ito, K. Yoshida, Theoretical analysis for a damping ratio of a jointed cantilever beam, *Bulletin of JSME* 16 (1973) 1421–1432.
- [6] N. Nishiwaki, M. Masuko, Y. Ito, I. Okumura, A study on damping capacity of a jointed cantilever beam (First Report; experimental results), *Bulletin of JSME* 21 (1978) 524–531.
- [7] N. Nishiwaki, M. Masuko, Y. Ito, I. Okumura, A study on damping capacity of a jointed cantilever beam (Second Report; comparison between theoretical and experimental values), *Bulletin of JSME* 23 (1980) 469–475.
- [8] N. Motosh, Stress distribution in joints of bolted or riveted connections, *Transactions of ASME, Journal of Engineering for Industry* 97 (1975) 157–161.
- [9] R. Connolly, R.H. Thornley, The significance of joints on overall deflection of machine tool structures, *Proceedings of the Sixth International MTDR Conference*, 1965, pp. 139–156.
- [10] K. Mitsunaga, *Transactions of Japan Society of Mechanical Engineers* 31 (1965) 1750.
- [11] H.H. Gould, B.B. Mikic, Areas of contact and pressure distribution in bolted joints, *Transactions of ASME, Journal of Engineering for Industry* 94 (1972) 864–870.
- [12] H.H. Ziada, A.K. Abd, Load, pressure distribution and contact areas in bolted joints, *Institution of Engineers (India)* 61 (1980) 93–100.
- [13] B.K. Nanda, Study of Damping in Structural Members under Controlled Dynamic Slip, PhD Thesis, 1992.
- [14] B.K. Nanda, A.K. Behera, Study on damping in layered and jointed structures with uniform pressure distribution at the interfaces, *Journal of Sound and Vibration* 226 (1999) 607–624.
- [15] B.K. Nanda, A.K. Behera, Damping in layered and jointed structures, *International Journal of Acoustics and Vibration* 5 (2000) 89–95.
- [16] B.K. Nanda, A.K. Behera, Improvement of damping capacity of structural members using layered construction, *Seventh International Congress on Sound and Vibration*, Garmisch-Partenkirchen, Germany, 2000, pp. 3059–3066.
- [17] C.J. Hartwigsen, Y. Song, D.M. McFarland, L.A. Bergman, A.F. Vakakis, Experimental study of non-linear effects in a typical shear lap joint configuration, *Journal of Sound and Vibration* 277 (2004) 327–351.
- [18] J.E. Shigley, *Machine Design*, McGraw-Hill Publication, New York, 1956.